

DPM 1/2 Pt - 4 Gal Specifications and Dimensions

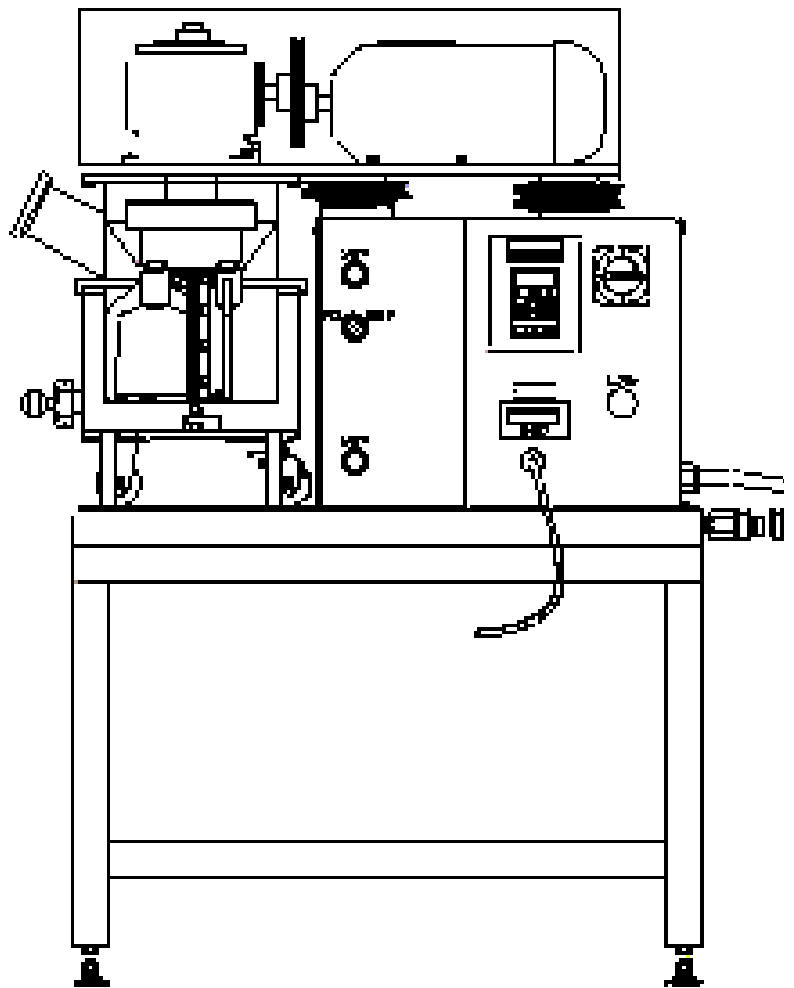

Model	Mixing Capacity	Full Capacity	HP	Orbital Speed	Stirrer Speed	Weight	Mix Can I.D.	Mix Can Depth	Mix Can OAH	Base Height	Overall length	Overall Width	Raised OAH	Lowered OAH
DPM 1/2 Pt	1/4 - 1/2 Pt	.1 Gal	1/3	10-30	30-90	165	3 1/2	2 1/2	3	1	21.5	12	23	24 1/2
DPM 1 Pt	1/2 - 1 Pt	.25 Gal	1/2	20-72	24-78	190	4 3/4	3 1/4	4 1/4	1	25	14 1/2	25 1/2	25 1/2
DPM 1 Qt	1/2 Pt - 1 Qt	.45 Gal	1/2	20-86	22-98	200	5 7/8	4	5	1	29	14 1/2	14 1/2	29
DPM 1 Gal	1 Pt-3 1/2 Qt	1 Gal	1-1.5	5-100	9-180	390	8 1/4	5	6 1/2	2 1/4	33 1/4	23	31 1/4	24 1/4
DPM 2 Gal	1 Qt - 1 1/2 Gal	2 Gal	1-1.5	5-100	6-120	450	9 5/8	6 1/2	8	2 1/4	35 1/4	23	32 1/4	24 7/8
DPM 4 Gal	1 Qt - 4 Gal	5 1/4 Gal	2	4-80	4-80	520	14	8	9 5/8	2 1/4	43 1/4	23	41 1/4	32 1/4
All dimensions are in inches													DPML 1101	

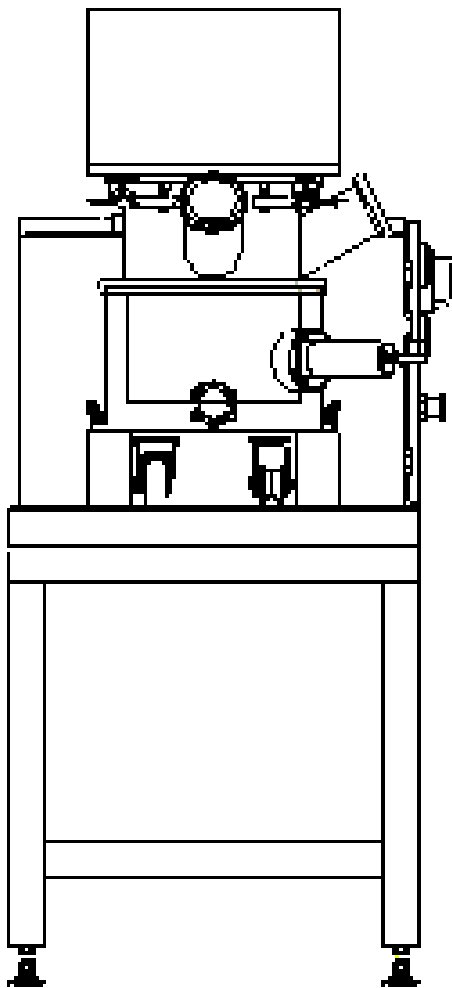

Charles Ross & Son Company

P.O.Box 12308, 710 Old Willets Path, Hauppauge, NY 11788 - Tel: 1-631-234-0500 - Fax: 1-631-234-0691

Website: www.mixers.com - Email: sales@mixers.com

DPM 1/2 Pt - 4 Gallon Standard and Optional Features

STANDARD FEATURES:

MATERIALS OF CONSTRUCTION:

Stainless Steel type 304 wetted parts polished to an 80 grit finish. All non-stainless steel exterior surfaces are coated with a high quality two-component paint.

CHANGE CAN DESIGN:

Change can design for use with multiple mix cans and Discharge Systems.

RAISE/LOWER:

Vertical lift design with air/oil hydraulic lift.

DRIVE/ELECTRICAL:

Agitators are driven by an explosion-proof inverter-duty motor. VFD drive provides variable speed operation and on/off operation of motor.

GEARBOX AND SEALS:

Stainless steel gearbox. Viton sealing O'Rings and Lip seals on stirrer shaft.

AGITATOR:

Rectangular stirrer blades are provided.

MIXING ENVIRONMENT:

Vacuum hood is easily removed providing access to upper gearbox area for simple maintenance and cleaning.

SAFETY FEATURES:

Explosion proof limit switches prevent operation of the mixer when in the raised position when the mix can is removed from the mixing position.

OPTIONAL FEATURES:

SPECIAL DESIGNS:

Equipment designed to meet vacuum, sanitary, explosive, internal pressure, or any other special processing environment. Vacuum drying and solvent recovery systems are available.

MATERIALS OF CONSTRUCTION:

Carbon steel, stainless steel, hastelloy, titanium or aluminum.

HYDRAULIC LIFT:

Motorized hydraulic lift with a self contained hydraulic pump/motor and raise/lower controls.

REVERSE LIFT DESIGN:

Reverse lift design in which upper bonnet is stationary and the mix can is raised into the mixing position.

DRIVE CONFIGURATIONS:

Mechanical variable speed motor drive, higher horsepower and special drive configurations to satisfy high torque requirements.

GEARBOX:

Fabricated in stainless steel with your choice of polished finishes and sealing arrangements. Additional dust and liquid seal arrangements available

STIRRER BLADES:

"HV" blades, finger type blades, augers, flight bars, custom designed agitators.

SCRAPERS:

Bottom scraper and self adjusting side wall scraper arm, supplied with replaceable scraper blades.

MIX CAN:

Jacketed vessels for heating or cooling, thermocouples for monitoring product temperature, discharge valves

POLISHING AND COATINGS:

Hard chrome plating, electropolish and high polish finishes up to mirror finish. Coatings of teflon, nylon, kynar, tungsten carbide, aluminum oxide and hastelloy.

SIGHT AND CHARGE PORTS:

Choice of any size charge/sight port, supplied with a solid end cap, pyrex sight glass, or a light for viewing. Hinged charging ports are also available.

MIXER BASE:

Raised bases are available to suit special filling and discharge requirements. Extended benches for mounting both a mixer and discharge system. Bases can be sheathed or made in stainless steel, aluminum, or other special materials.

OPERATOR CONTROLS:

Choice of all NEMA enclosure ratings including explosion-proof, and intrinsically safe. Custom designed PLC control systems are available.

DISCHARGE SYSTEMS:

Discharge Systems provide complete "Hands-Free" discharge of product, directly from the mix can. Floor mounted and Elevated designs are available for discharge into your choice of container, drums, cartridges or small syringes.

AUTOMATED MIXING AND DISCHARGE SYSTEMS:

Completely Automated Turntable System, featuring Filling, Mixing and Discharge Stations with PLC Controls.

AUXILIARY EQUIPMENT:

Vacuum Pumps, Vent Condensers, Temperature Control Systems, Load Cells, Pump & Metering Systems, Etc.